

Ceramic Shear

Type 8290A25M5

High Sensitivity, Charge Mode, Triaxial Accelerometer

Designed for long-term, high operational temperature stability at 250°C, the 8290A25M5 accelerometer simultaneously measure shock and vibration in three orthogonal axis.

- High impedance, charge mode
- Ceramic Shear sensing element
- High Temperature (250 °C) version available
- Low transverse sensitivity
- Long-term stability at extended temperatures

Description

The 8290A25M5 high temperature, triaxial accelerometer is housed in a cube-shaped package with a notched corner to aid in orientation during installation in blind areas. Laser-etched markings on all sides clearly identify the three axes. A ceramic shear sensing element produces a charge output that can be easily converted into a useable analog voltage signal via a charge amplifier. Kistler's shear technology assures high immunity to base strain, thermal transients and transverse accelerations. Other outstanding features include high frequency response, lightweight and hermetic sealing. It is recommended that low noise transducer cables be used between the sensor and charge amplifier, such as Kistler 1635 series.

Internal of this hermetically sealed accelerometer, is a shear mode, ceramic sensing element, providing a significant charge output. Type 5050A(X) In-Line Charge Amplifier is recommended for use with the 8290A25M5. The 5050A(X) is a lower cost alternative to the laboratory amplifier allowing the measurement system to take on the appearance of the traditional voltage mode accelerometer and power supply/coupler.

Application

The 8290A25M5 is recommended for general vibration measurements in high temperature and in confined areas. Applications for this accelerometer include vehicle vibration and NVH testing, general laboratory, environmental testing where low impedance sensors are limited by temperature range. It can also be used in ESS, and modal analysis applications.

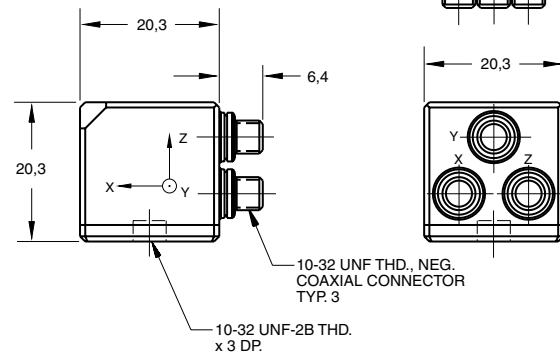
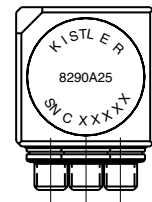
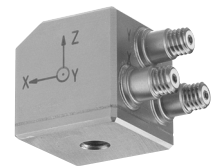

CE Compliant Information

Because high impedance, charge mode accelerometers contain no electronics, CE certification to the EMC Directive is not appropriate. When a high impedance accelerometer is used with a CE certified signal conditioner (i.e., charge amplifier...), it is said that this system is CE compliant.

000-215e-08.03 (K8.8290M5)

Technical Data

Type	Units	8290A25M5
Acceleration Range	g	± 2000
Acceleration Limit	g _{pk}	± 2000
Threshold nom.	g _{rms}	0,001
Sensitivity ± 15% (@ 10 g & 100 Hz)	pC/g	-25
Resonant Frequency mounted, nom.	kHz	20
Frequency Response		
stud mounted ±10%	Hz	5 ... 4000
adhesive mounted ± 10%	Hz	5 ... 2000
Amplitude Non-Linearity	% FSO	±1
Insulation Resistance @ 23 °C	Ω	1 x 10 ⁸
250 °C	Ω	1 x 10 ⁸
Capacitance	pF	1300
Transverse Sensitivity typ., (max. 3%)	%	1,5
Environmental:		
Base Strain Sensitivity @ 250µε	g/µε	0,01
Shock Limit (1ms pulse)	g _{pk}	5000
Temperature Coefficient of Sensitivity	%/°C	0,13
Temperature Range Operating	°C	-70 ... 250
Temperature Range Storage	°C	-80 ... 260
Construction:		
Sensing Element	type	ceramic/shear
Housing/Base	material	st. stl
Sealing-housing/connector	type	hermetic
Connector	type	10-32 neg.
Weight	grams	53
Mounting Torque	Nm	2

1 g = 9,80665 m/s², 1 inch = 25,4 mm, 1 gram = 0,03527 oz, 1 lbf-in = 0,1129 Nm

Mounting

Reliable and accurate measurements require that the mounting surface be clean and flat. The accelerometer can be attached to the structure utilizing the supplied 10-32 mounting stud or adhesive. The Operating Instruction Manual for the 8290A25M5 provides detailed information regarding mounting surface preparation.

Related Products

- 8202A10 1000 g range, side connector, -10 pC/g
- 8203A50 2000 g range, side connector, -50 pC/g

Ordering Information

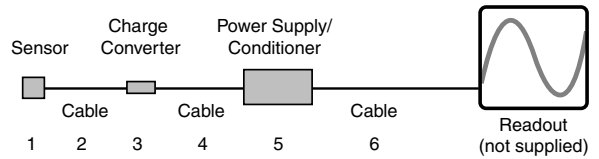

sp = specify cable length in meters

- 1 - 8290A25M5 high temperature accelerometer
- 2 - 1635Csp premium low noise cable, or 1635Asp low noise cable
- 3 - 5050A(X) series charge converter
- 4 - 1511sp output cable, BNC pos. to BNC pos.
- 5 - 5100 coupler series or dual mode amplifier
- 6 - 1511sp output cable, BNC pos. to BNC pos.

Supplied Accessories

- 8402 10-32 thd. mounting stud

Optional Accessories

- 8452A mounting magnet
- 8411 10-32 thd to M6 mounting stud

000-215e-08.03 (K8.8290M5)