

Ceramic Shear Accelerometer

Type 8772A...

Light Weight, Voltage Mode, Modal Accelerometers

Light weight, cube shaped accelerometer for vibration measurements in multichannel modal test applications. Cube shaped design allows two units to be placed side by side with sensitive axis oriented to measure acceleration along orthogonal axis.

- Low impedance voltage mode
- Lightweight, ceramic shear modal sensor
- Durable hard anodized, aluminum housing for ground isolation
- Cube shaped for mounting flexibility
- Conforming to CE

Description

A unique shear element design coupled with an advanced hybrid charge amplifier provides outstanding phase response as well as a wide frequency range. The accelerometer housing is environmentally (epoxy) sealed with a durable, hard anodized finish that electrically isolates the unit from the test structure. The flat sides of the cube housing allow for dual axis unit arrangements and flexible attachment to the test structure. The use of several 8474 mounting clips facilitates single unit roving on a test structure.

The built-in charge amplifier provides a low impedance voltage output, allowing the use of standard low cost cabling. These accelerometers will operate directly from the internal power source available in most FFT analyzers or from a large selection of Kistler power supply couplers.

Application

The lightweight ceramic shear design is ideally suited for use in modal test applications where mass loading on very light structures is an important measurement concern.

Aerospace and Automotive vehicle structure testing; air frame flight flutter test, product development test are but of the few application areas suitable for this accelerometer series.

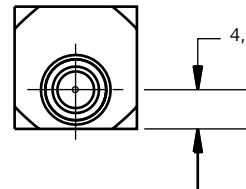
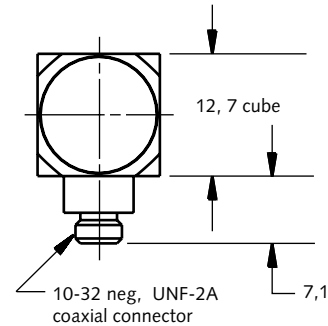

Accessing TEDS Data

Accelerometers with a "T" suffix are variants of the standard version incorporating the "Smart Sensor" design. Viewing an accelerometer's data sheet requires an Interface/Coupler such as Kistler's Type 5134B... or 5000M04 with TEDS Editor software. The Interface provides negative current excitation (reverse polarity) altering the operating mode of the PiezoSmart sensor allowing the program editor software to read or add information contained in the memory chip.

8772A_000-253e-02.07

Technical Data

| Type | Unit | 8772A5 | 8772A10 | 8772A50 |
|-----------------------------------|----------|-------------------|-------------------|-------------------|
| Acceleration Range | g | ±5 | ±10 | ±50 |
| Acceleration Limit | gpk | ±8 | ±16 | ±80 |
| Threshold nom. | grms | 0,0004 | 0,0005 | 0,002 |
| Sensitivity (±5%) | mV/g | 1000 | 500 | 100 |
| Resonant Frequency mounted, nom. | kHz | 20 | 20 | 20 |
| Frequency Response, ±5% | Hz | 1 ... 5000 | 1 ... 5000 | 1 ... 5000 |
| Phase Shift, <5° | Hz | 2 ... 3000 | 2 ... 3000 | 2 ... 5000 |
| Amplitude Non-linearity | %FSO | ±1 | ±1 | ±1 |
| Time Constant nom. | s | 1 | 1 | 1 |
| Transverse Sensitivity max. | % | 5 | 5 | 5 |
| Long Term Stability | % | ±1 | ±1 | ±1 |
| Environmental: | | | | |
| Base Strain Sensitivity @ 250µε | g/µε | <0,005 | <0,005 | <0,05 |
| Shock Limit (0,2 ms pulse) | gpk | 5000 | 7000 | 7000 |
| Temperature Coeff. of Sensitivity | %/°C | -0,15 | -0,10 | -0,10 |
| Temperature Range Operating | °C | 0 ... 65 | 0 ... 65 | 0 ... 65 |
| Temperature Range Storage | °C | -23 ... 94 | -23 ... 94 | -23 ... 94 |
| Output: | | | | |
| Bias nom. | VDC | 11 | 11 | 11 |
| Impedance | Ω | <500 | <500 | <100 |
| Voltage full scale | V | ±5 | ±5 | ±5 |
| Current | mA | 2 | 2 | 2 |
| Source: | | | | |
| Voltage | VDC | 20 ... 30 | 20 ... 30 | 20 ... 30 |
| Constant Current | mA | 2 ... 18 | 2 ... 18 | 2 ... 18 |
| Impedance min. | kΩ | 100 | 100 | 100 |
| Construction: | | | | |
| Sensing Element | type | Ceramic/Shear | Ceramic/Shear | Ceramic/Shear |
| Housing/Base | material | Al. Hard Anodized | Al. Hard Anodized | Al. Hard Anodized |
| Sealing-housing/connector | type | Epoxy | Epoxy | Epoxy |
| Connector | type | 10-32 UNF neg. | 10-32 UNF neg. | 10-32 UNF neg. |
| Ground Isolated min. | MΩ | 10 | 10 | 10 |
| Weight | grams | 8 | 8 | 8 |
| Mounting (thread/stud) | type | Wax/Adhesive | Wax/Adhesive | Wax/Adhesive |

 1 g = 9,80665 m/s², 1 Inch = 25,4 mm, 1 gram = 0,03527 oz, 1 lbf-in = 0,1129 Nm

Mounting

Reliable and accurate measurements require that the mounting surface be clean and flat. The accelerometer can be attached to the test structure by using wax, adhesive or by a 8474 mounting clip. The operating instruction manual for the 8772A... series provides detailed information regarding mounting surface preparation, proper application of adhesive, and the dimensional configuration of the mounting clip.

Accessories Included

- Mounting wax

Type
8432

Optional Accessories

- Mounting clip, Black Delrin

Type
8474

Ordering Key

| Range | |
|-------|----|
| ±5g | 5 |
| ±10g | 10 |
| ±50g | 50 |

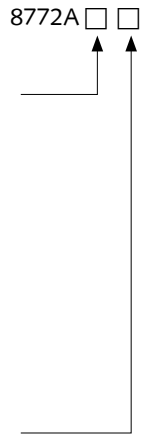

TEDS Templates

| | |
|---|-----|
| Standard | - |
| Default, IEEE 1451.4 V0.9 Template 0 (UTID 1) | T |
| IEEE 1451.4 V0.9 Template 24 (UTID 116225) | T01 |
| LMS Template 117, Free format Point ID | T02 |
| LMS Template 118, Automotive Format (Field 14 Geometry = 0) | T03 |
| LMS Template 118, Aerospace Format (Field 14 Geometry =1) | T04 |
| P1451.4 v1.0 template 25 - Transfer Function Disabled | T05 |
| P1451.4 v1.0 template 25 - Transfer Function Enabled | T06 |

Measuring Chain

- | | Type |
|--|-------------|
| 1 Low impedance sensor | 8772A... |
| 2 Sensor cable, 10-32 pos. to BNC pos. | 1761B... |
| 3 Power supply/Signal conditioner | 5134B... |
| 4 Outout cable, BNC pos. to BNC pos. | 1511 |

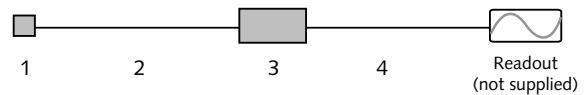

8772A_000-253e-02.07